

2nd Gear Super Hold Servo Kit

Part No.

22301B-01K

- Cover
- Piston
- Sleeve
- Pin
- Retaining Ring
- Seals/Seal Rings (5)
- O-Rings (3)

Replacement Seal Kit

Part No.

22301B-SK

- Seals/Seal Rings (5)
- O-Rings (3)

Also Available

High Strength Band Strut

22825-01

Accumulator Piston Kit

22841-04K

Chrysler A727, 46/47RH, 46/47/48RE

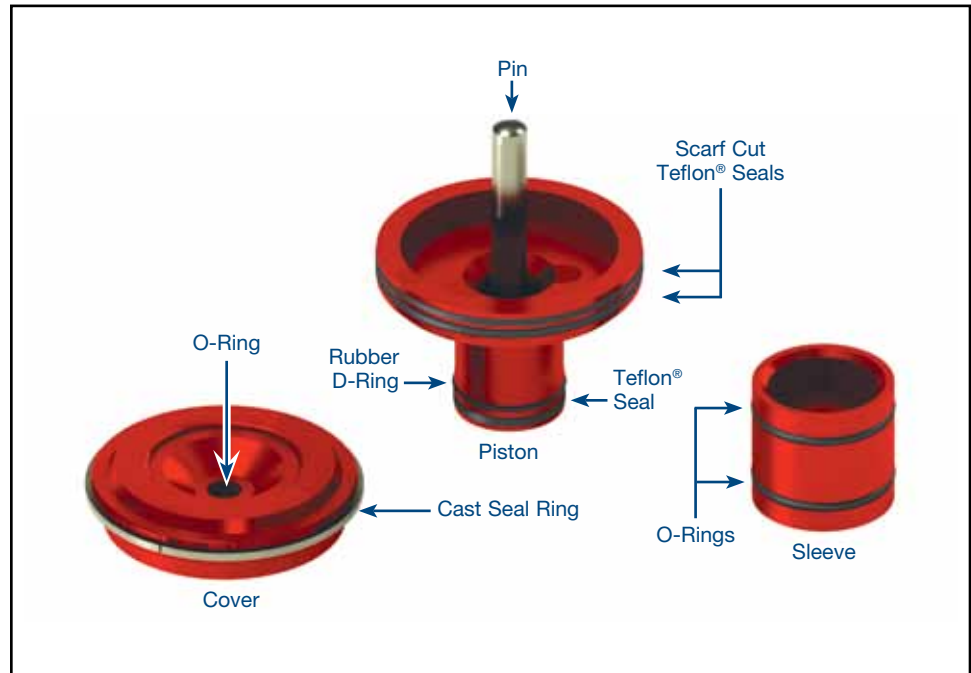

This Sonnax 2nd gear servo offers 16% more apply area than the OE servo and is the largest and most leak-free servo available. The small and large diameters of both the piston and cover have improved sealing which eliminates cross leaks and results in 15% less leakage than other designs. Less leakage means there is more pump volume available for the converter and to maintain line pressure.

The rubber and Teflon® seals enhance positive sealing and prevent piston contact and bore scuffing. The smaller diameter apply pin gives more area to the release side of the servo where direct clutch oil pushes the servo off during the 2-3 shift. This increased area balances against the greater 2nd apply area to maintain a favorable apply-to-release area ratio and minimize shift overlap on the 2-3 shift. The overall result is more holding force in 2nd, firmer 1-2 and 2-3 shifts that become firmer under load.

For higher horsepower applications, this servo reduces the need for aggressive lever ratios, excessively high line pressure and other more radical modifications in order to get firmer shifts.

Features & Benefits

- 16% more apply area provides more band holding power in 2nd gear
- One easy-to-install part improves 1-2 and 2-3 shifts
- Improved seal design conserves pump volume
- Anodized aluminum for increased durability