

## Oversized Lube Regulated PR Valve Kit

### 22771A-07K

- 1 Pressure Regulator Valve
- 1 Throttle Pressure Plug
- 1 Pressure Regulator Spring



### F-22771A-TL7

- 2 Reamers
- 2 Reamer Jigs
- 2 Bore Guide Pins



### Valve Body Inspection

1. If a line-to-lube hole has been drilled in the PR valve circuit, it should be plugged to reduce converter drainback.
2. Inspect the line pressure plug and sleeve. Leakage here will result in poor line pressure control.
3. Inspect the TV checkball separator plate seat. Leakage here may produce stacked shifts and/or no kickdown.

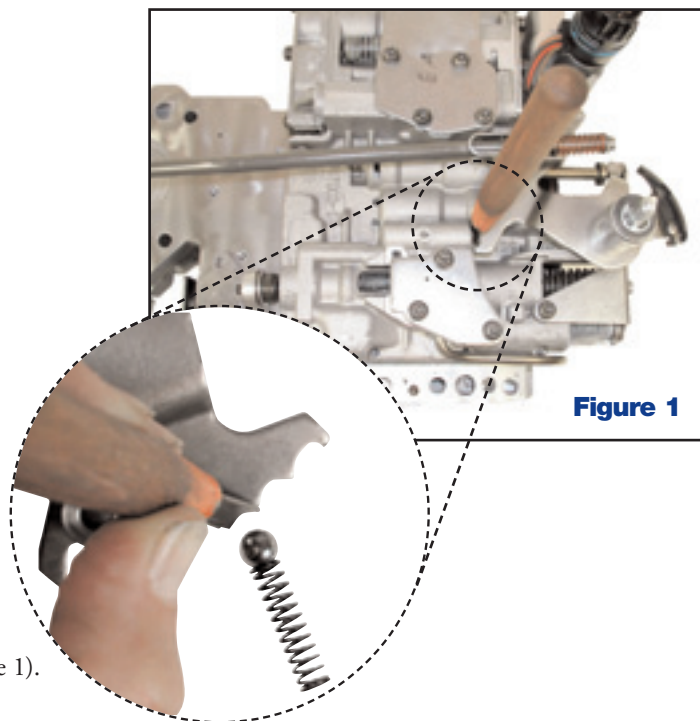
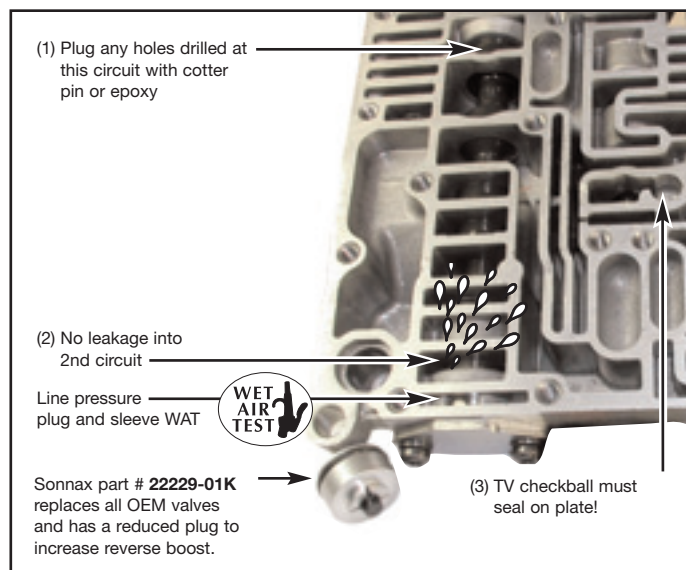
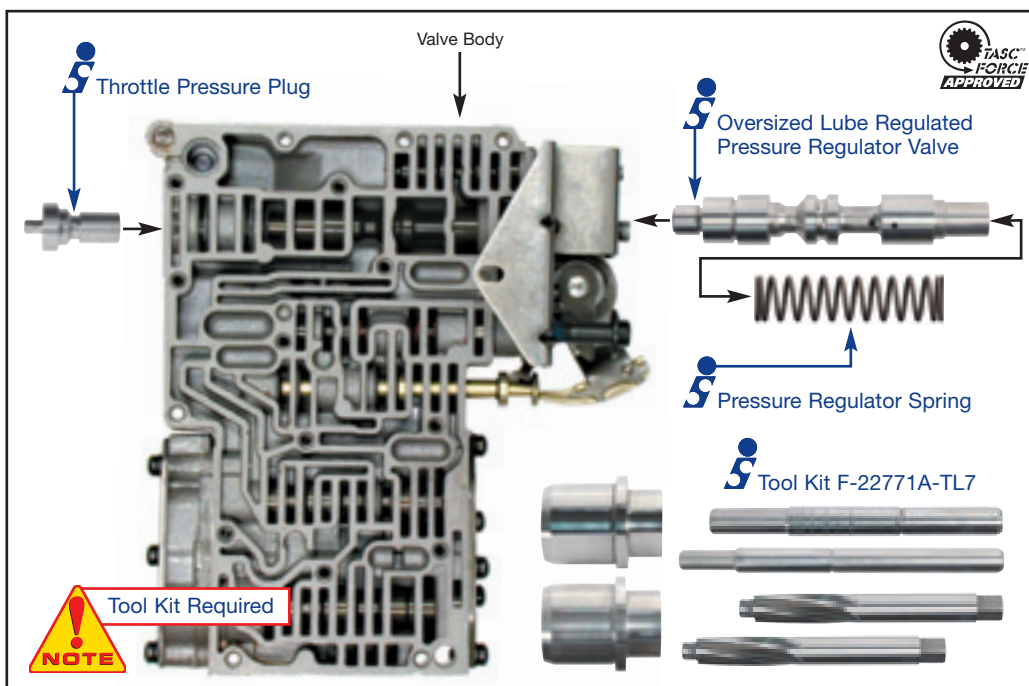

Figure 1

### Disassembly Instructions

1. Remove the detent assembly and spring retainer bracket (see Figure 1).
2. Remove the original pressure regulator spring and valve.
3. Remove the end plate on the opposite side of the bore and remove the line pressure plug and sleeve, throttle pressure plug and the spring (see Figure 3).
4. Keep all components removed in steps 2 and 3 except for the pressure regulator valve, spring and the throttle pressure plug for reassembly.
5. Clean the bore.

# CHRYSLER RWD ('78-UP W/TCC)

PART NUMBERS 22771A-07K, F-22771A-TL7

**Oversized Lube  
Regulated PR Valve Kit**

## Reaming Instructions

### Prep and Set-up:

1. Clean the bore thoroughly in a solvent tank.
2. Align valve body in fixture according to **VB-FIX** instructions with the appropriate guide pin provided in tool kit **F-22771A-TL7**. To align the pressure regulator valve use jig **F-22771A-RJ** and guide pin **F-22771A-GP**, then ream with reamer **F-22771A-RM**. To align the throttle pressure plug bore use jig **F-22771A-RJ2** and guide pin **F-22771A-GP2**, then ream with reamer **F-22771A-RM2**.
3. Soak the bore and reamer with cutting fluid (Mobilmet S-122, Lubegard Bio-Tap, Tap Magic™, etc). For best results, provide a continuous flow of water-soluble cutting fluid (i.e. Mobilmet S-122) during the reaming process.
4. Gently insert the reamer through the jig and into the bore until the cutting tip contacts the first bore to be reamed.
5. Select the correct sized socket to fit the square shank of the reamer, and attach it to a wobble/swivel socket drive.

### Reaming:

1. The reamer should be turned either by hand using a speed handle or by a low rpm, high torque air drill regulated to a maximum of 200 rpm.
2. The reaming action should be clockwise in a smooth and continuous motion, at 60-200 rpm. The reamer should actually pull itself through the bore, so little or no forward force should be applied.
3. Continue reaming until the reamer stop is reached. The approximate reaming time is 2-3 minutes.

### Finish and Clean-up:

1. With low air pressure, blow the chips free before removing reamer.
2. To remove the reamer, turn clockwise while slowly pulling outward on the reamer.
3. Remove any remaining debris from the bore with low air pressure and clean in a solvent tank.
4. Examine the bore after cleaning for surface finish, debris, and burrs. Flashing and burrs on the exit side of casting bores can be carefully removed with a small piece of Scotchbrite™ on the end of a long wire.
5. Clean the reamer after each use and store in its protective tube.

### Cautions and Suggestions:

1. Turning the reamer backward will dull it prematurely.
2. Pushing on the reamer will result in poor surface finish, and inadequate and sporadic material removal.
3. Never use a crescent wrench, ratchet or pliers to turn the reamer.
4. A dull reamer will cut a smaller hole. Reamers can be sharpened, but should only be done by a professional tool sharpener. Actual life of a reamer before resharpening averages 50-70 bores.

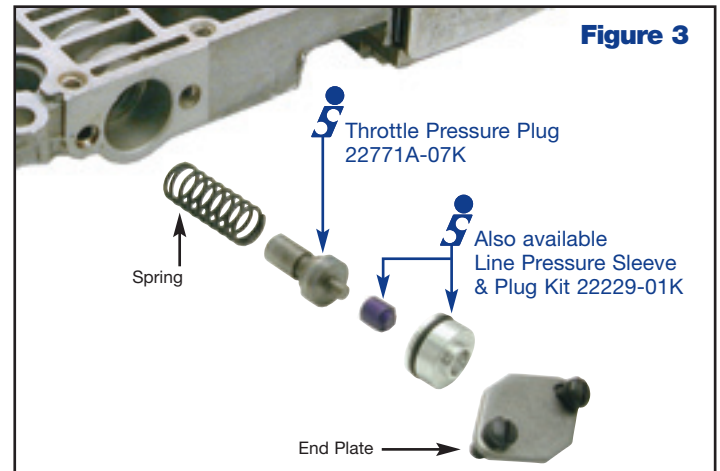
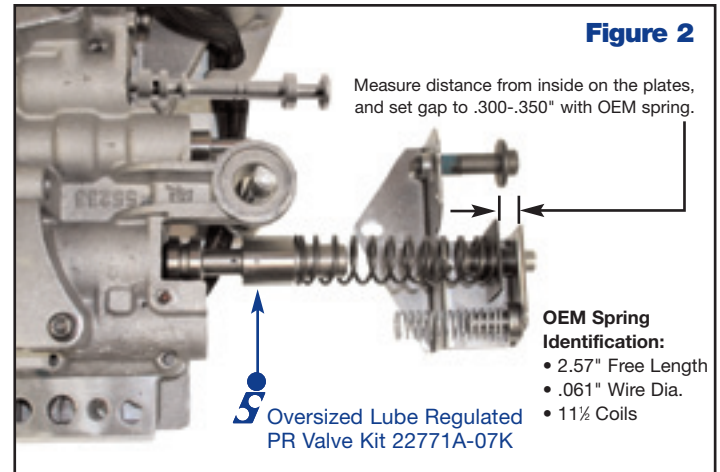

## Installation Instructions

1. Install the Sonnax oversized lube regulated pressure regulator valve, spring and OE spring retainer bracket (see Figure 2).
2. At the opposite end of the bore install the OE spring, the Sonnax oversized throttle pressure plug and the pressure plug and sleeve assembly.
3. Install the end cap with the two screws.
4. Adjust the pressure regulator adjusting screw so that there is a .300-.350" gap between the inside of the plates (see Figure 2). Line pressure should be 62-65 psi idle at drive.
5. Line pressure should be verified with a gauge after installation (pressure tap on the passenger side, middle of the case, between accumulators).

**Important Note:** Line pressure in excess of 80 psi may cause binding due to cross leaks and excessive throttle sensitivity.

  
TIME TESTED • INDUSTRY TRUSTED™