

Oversized Lube Regulated PR Valve & Line/TV Pressure Plug Kit

22771A-16K

- 1 OS Pressure Regulator Valve
- 1 OS Line/TV Pressure Plug Assembly
- 1 Pressure Regulator Spring



F-22771A-TL7

- 2 Reamers
- 2 Reamer Jigs
- 2 Bore Guide Pins

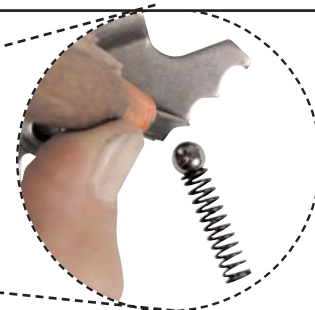
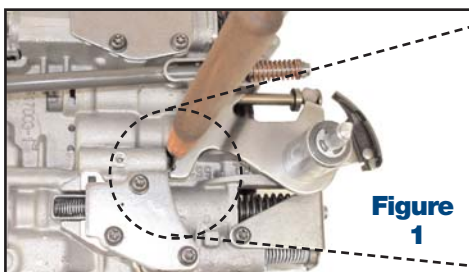
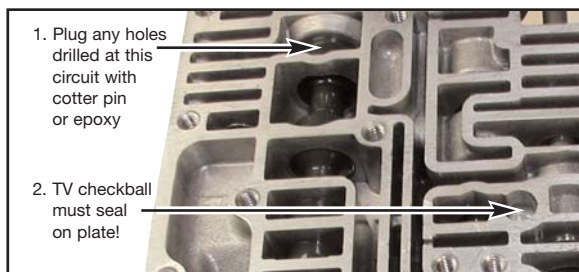
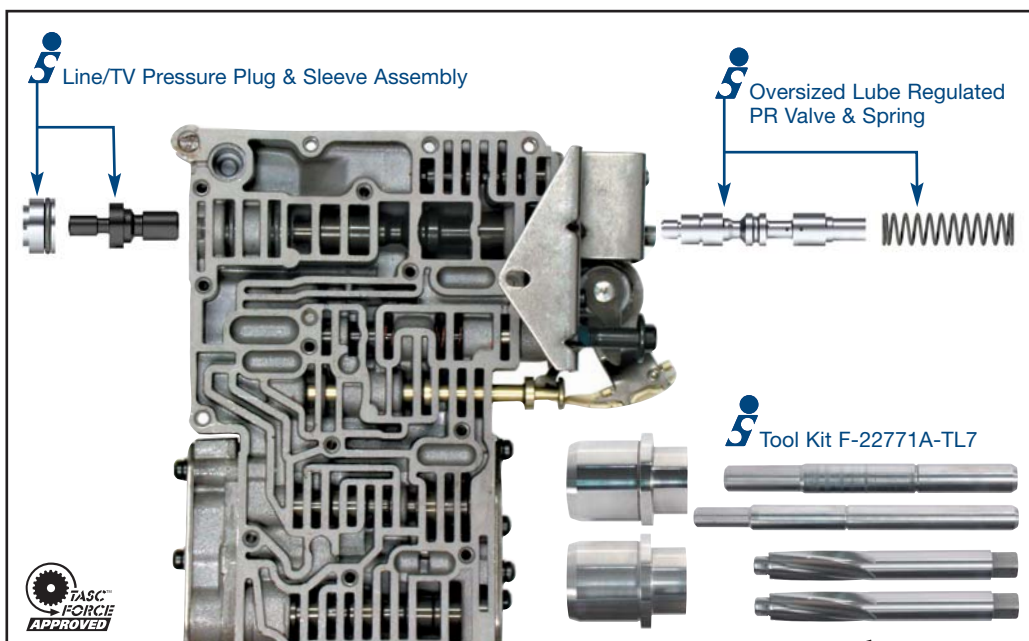

Figure 1

Valve Body Inspection

1. If a line-to-lube hole has been drilled in the PR valve circuit, it should be plugged to reduce converter drainback.
2. Inspect the TV checkball separator plate seat. Leakage here may produce stacked shifts and/or no kickdown.

Disassembly Instructions

1. Remove the detent assembly & spring retainer bracket, *see Figure 1*.
2. Remove the original pressure regulator spring and valve.
3. Remove the end plate on the opposite side of the bore and remove the line/TV pressure plug and sleeve assembly and the spring.
4. Keep the OEM line/TV pressure plug spring and the end plate. Discard all other OEM components.
5. Clean the bore thoroughly in a solvent tank.

Prep & Set-up:

Align valve body in fixture according to VB-FIX instructions with the appropriate guide pin provided in tool kit F-22771A-TL7. To align the pressure regulator valve use jig F-22771A-RJ and guide pin F-22771A-GP, then ream with reamer F-22771A-RM. To align the throttle pressure plug bore use jig F-22771A-RJ2 and guide pin F-22771A-GP2, then ream with reamer F-22771A-RM2.

Important Notes:

1. Generously lubricate the bore and reamer with cutting fluid (i.e. Mobilmet S-122, Lubegard Bio-Tap, Tap Magic™, etc). For best results, provide a continuous flow of water-soluble cutting fluid (i.e. Mobilmet S-122) during the reaming process.
2. The reamers should be turned using a low rpm, high torque air drill regulated to a maximum of 200 rpm.
3. Examine the bore after cleaning for surface finish, debris, and burrs. Flashing and burrs on the exit side of lands and bores must be carefully removed. A small piece of Scotchbrite™ material attached to a wire and powered with a drill motor is ideal for the task.

Cautions and Suggestions

1. Turning the reamer backward will dull it prematurely.
2. Pushing on the reamer will result in poor surface finish and inadequate and sporadic material removal.
3. Never use a crescent wrench, ratchet or pliers to turn the reamer.
4. A dull reamer will cut a smaller hole. Reamers can be sharpened, but should only be done by a professional tool sharpener. Actual life of a reamer before resharpening or replacing averages 50-70 bores.

CHRYSLER 48RE

Oversized Lube Regulated PR Valve and Line/TV Pressure Plug Kit

PART NUMBERS 22771A-16K, F-22771A-TL7

Reaming Instructions

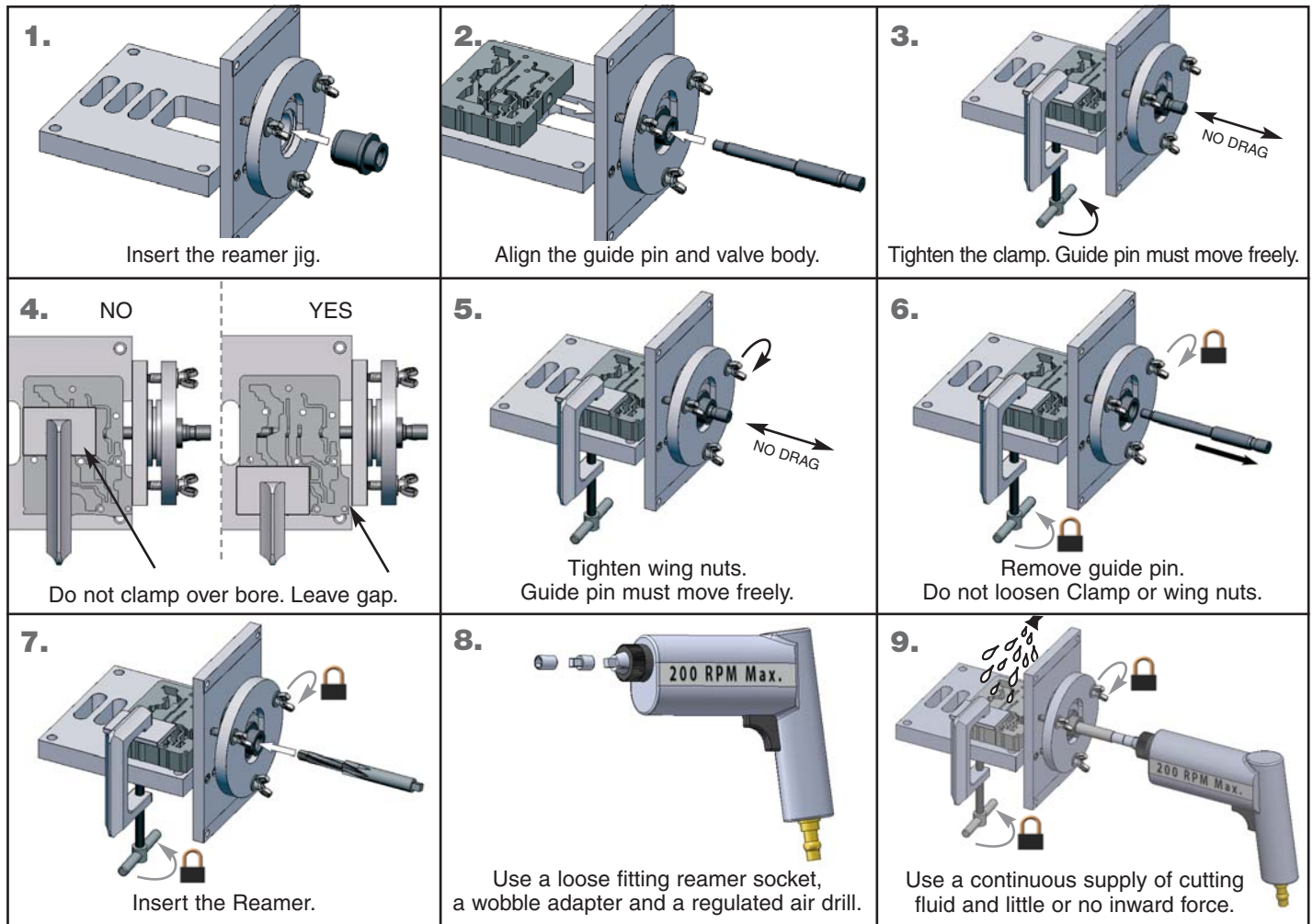

Installation Instructions

1. Install the Sonnax oversized lube regulated pressure regulator valve, matched spring and OE spring retainer bracket (see Figure 2).
2. At the opposite end of the bore install the OE spring, the Sonnax oversized line/TV pressure plug and sleeve assembly.
3. Install the end cap with the two screws.

Note: Check to be sure the end cap (plate) sits flush against the valve body and seals the bore. If the plate is not flush, remove material from the castellated side of the o-ringed sleeve. Remove the minimum material necessary to allow the plate to seal the bore. Do not remove more than .015" [0.38 mm] total from the sleeve. Pressure leaking at the plate will result in increased line pressure.

4. Adjust the pressure regulator adjusting screw so that there is a .300-.350" gap between the inside of the plates (see Figure 2). Line pressure should be 62-65 psi idle at drive.
5. Line pressure should be verified with a gauge after installation (pressure tap on the passenger side, middle of the case, between accumulators).

Important Note: Line pressure in excess of 80 psi may cause binding due to cross leaks and excessive throttle sensitivity.

