

## Late Model Low Sprag Update

### 56600B-01K

2 End Caps  
1 Rear Sprag Inner Race  
1 Thrust Washer

### 56600B

1 Rear Sprag Inner Race - 4.0L  
(2.70" race diameter)

### 56250-01K

2 End Caps  
1 Thrust Washer

### 56600-DJ

1 Drill Jig  
1 Dowel Pin

**Note:** Recommended tool for 56600B, 56600 and 56600B-01K

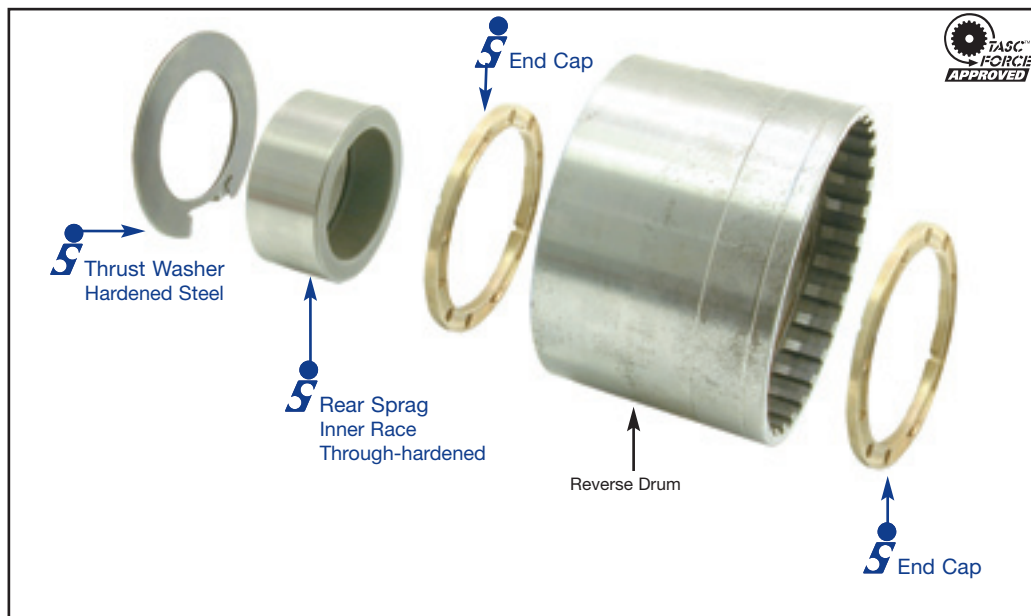

### Installation Instructions

**Note:** Use of drill jig suggested and explained below. Race can be removed or installed without jig, but it's more difficult (see instructions).

1. Align drill jig so that  $\frac{5}{16}$ " dowel pin hole is toward bottom of the case (oil pan). Install dowel pin into drill jig so that it goes into the bottom pocket in the case as shown in Figure 1.

**FIGURE 1**

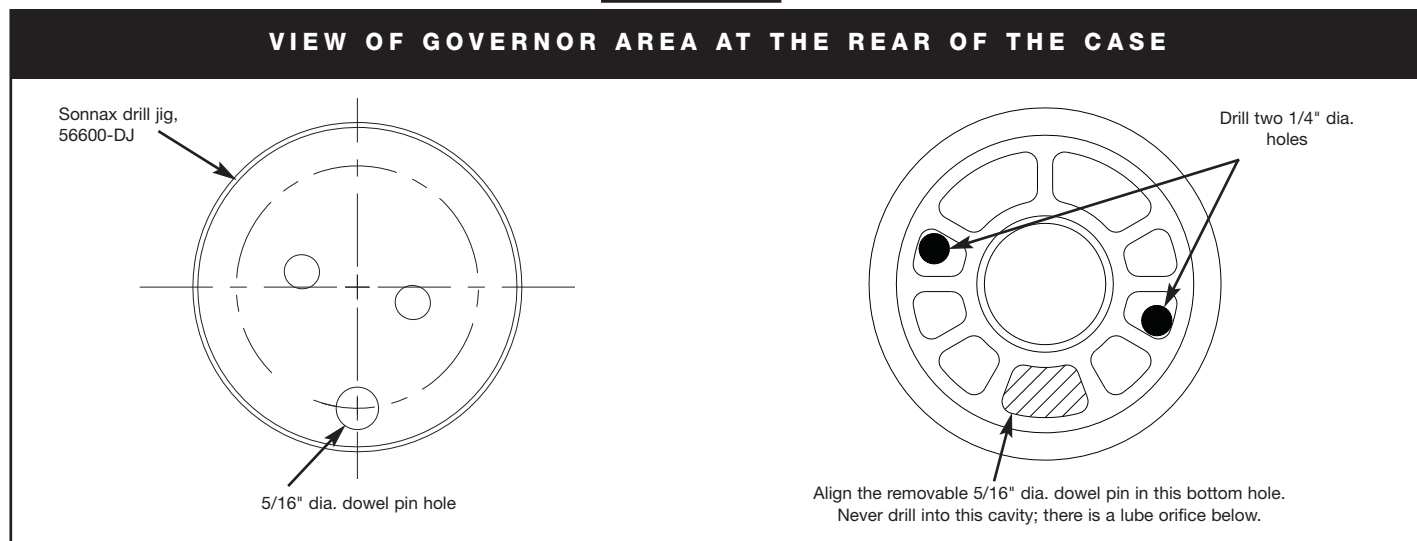

PART NUMBERS 56600B-01K, 56600B, 56250-01K, 56600-DJ

### Installation Instructions (continued)

- Using a  $\frac{1}{4}$ " drill bit, drill two holes at a  $15^\circ$  angle as shown in Figure 2. If the drill jig is not used, estimate the  $15^\circ$  angle.
- After verifying that the holes are contacting the steel race, use a  $\frac{1}{2}$ " drift punch to drive the inner race from the case. Alternate driving the race from both sides so that the race does not become cocked during removal.
- Install the new steel thrust washer and retain it with Trans-Jel™. Steel washer must sit flat on case. Sometimes the locating tab contacts the case and lifts the washer. If tab prevents flush fit, grind tab narrower to fit.
- Position the inner race on the case with flattened splines first (toward steel washer). Remove dowel pin from drill jig and use to support the governor area as shown in Figure 3, then press the inner race onto the case until flush. **CASE MUST BE SUPPORTED WHEN RACE IS PRESSED ON!** The drill jig is the press support. If you must drive the race on with a hammer, **BE SURE TO SUPPORT CASE** and **PROTECT RACE**. Sonnax race has longer internal splines that cut into case. These splines increase holding but also increase press force for reinstall. Verify the race is pressed completely onto washer and the race is flush with the case snout.
- Replace the original bronze scoop washers with the bronze sprag end caps.

**FIGURE 2**

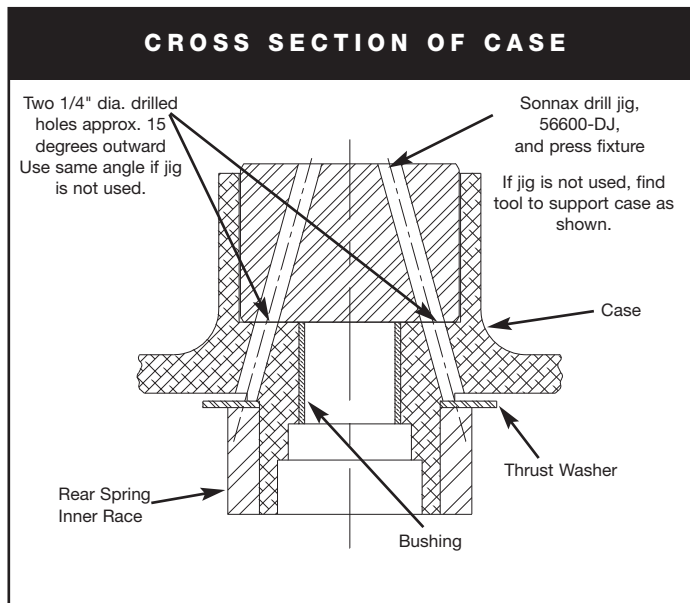

**FIGURE 3**

