

## Pressure Regulator Valve Kit

### 73840-RK

1 Converter Regulator Valve  
1 OS Pressure Regulator Valve  
4 Lubrication Plugs (1 extra)  
1 Spring  
U.S. Patent Nos. 6,543,472 & 6,585,002



### 73840-RTL

Services 73840-RK only  
1 Reamer  
1 Drill Jig  
3 Drill Bits (for lube modification)

Also Available:

### 73840-DK

3 Drill Bits (for lube modification)

Note: Patent Pending

### 73840-MK

Master Kit includes

73840-RK - Pressure Regulator Valve Kit  
73840-BK - Bypass Clutch Control Kit



### 73840-MTL

Master Tool Kit includes

73840-RTL Services 73840-RK only  
73840-BTL Services 73840-BK only

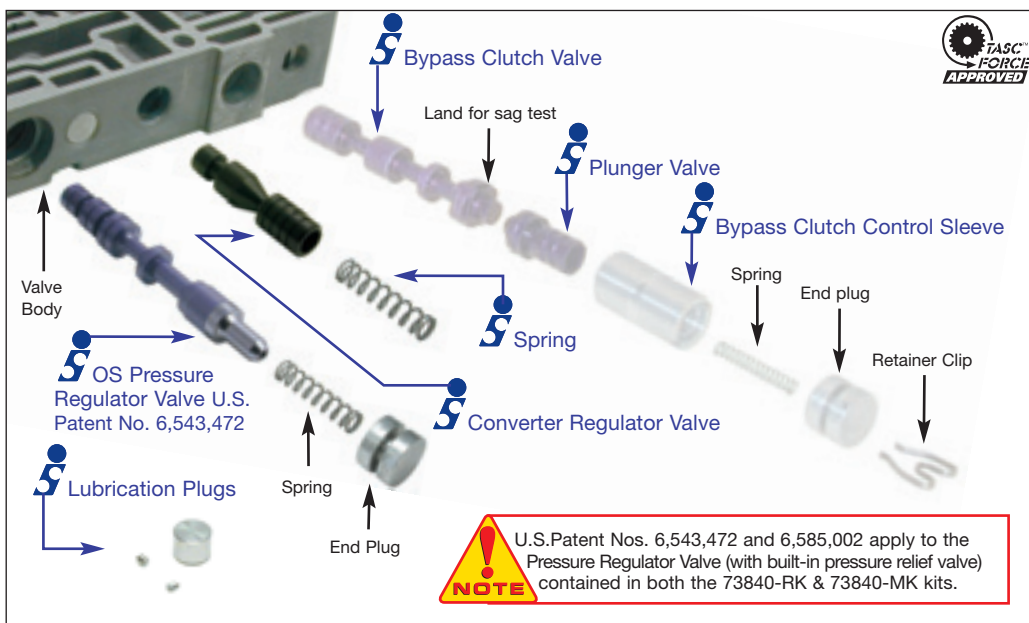

### CD4E Pressure Testing

Poor Pressures: Listed below, result from worn valve bodies and loose bushings.

- Less than 2 psi when hot
- Less than 10 psi when cold
- Less than 20 psi when hot
- More than 110 psi at TCC apply

← Front Lube

← - CT - Converter Turbine psi

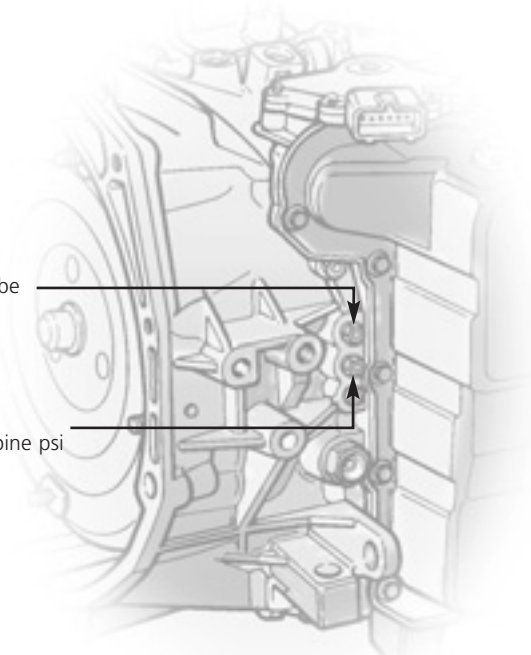

All pressure tests are taken in drive range.

# CD4E, LA4A-EL

## Pressure Regulator Valve Kit

PART NUMBERS 73840-RK, -RTL

### Wet Air Test

To Wet Air Test the pressure regulator valve bore for excessive wear, refer to the following photo. Place a small amount of oil into the indicated CBY (converter bypass) circuit and follow with low air pressure while plugging the indicated ports, one at a time. There should be no leakage past the valve spool during WAT.

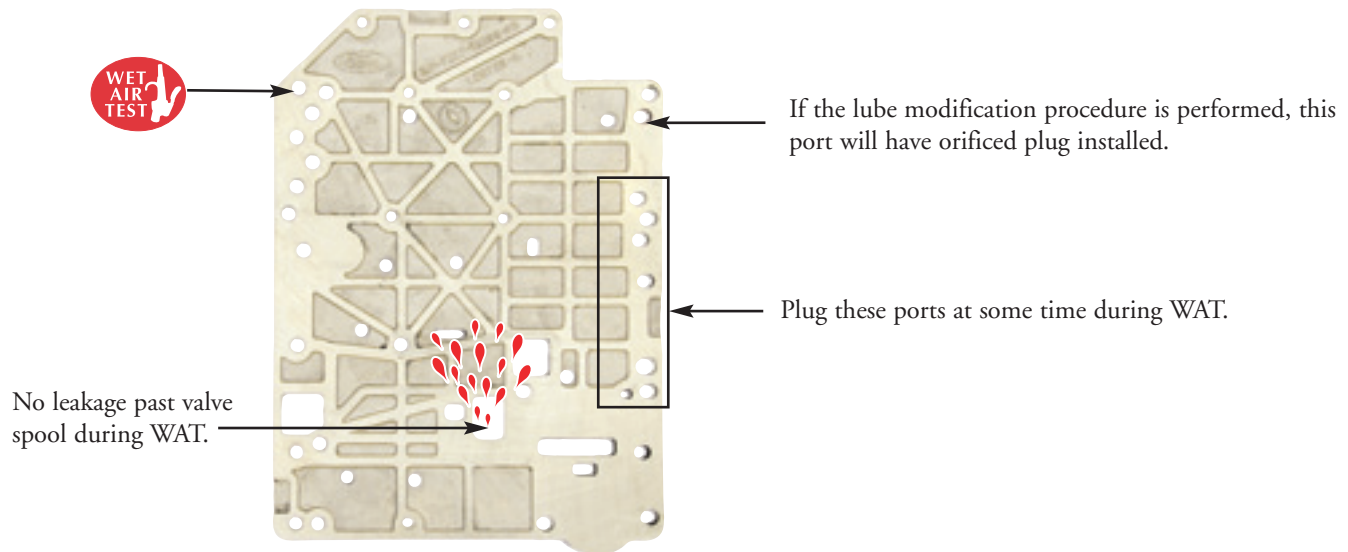

### Wiggle Test

A visual inspection and valve tolerance/clearance wiggle test can be performed by prying on both sides of the valve while still in the bore, and looking at the locations marked with an "X".

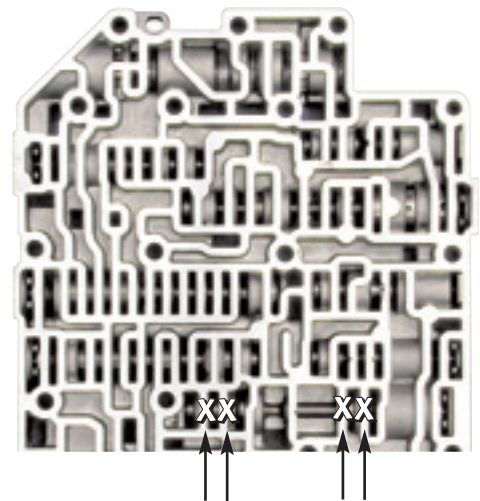

## Reaming

1. Remove valves from the bore to be reamed.
2. Clean valve body.
3. Clamp the valve body to bench with open circuits up.
4. Fill bore with cutting fluid (kerosene, Tap Magic™, etc.).
5. Insert the reamer jig into bore.
6. Soak fluted end of reamer with cutting fluid.
7. Insert reamer into reamer jig until reamer tip contacts the first bore to be cut. Securely position the reamer against the bore to remove any reamer wobble. The chamfer at the reamer tip will help stabilize and center the reamer.
8. With the reamer carefully and securely positioned, use a speed handle to ream the bore. The reaming action should be clockwise in a smooth and continuous motion, at approximately 1 to 1½ revolutions per second.
9. The reamer should actually pull itself through the bore, so little or no back pressure should be applied to the reamer or speed handle.
10. Continue reaming until the tip of the reamer bottoms in the bore. Spin the reamer 5-10 more times after bore bottoming to allow for excess material removal and better surface finish.
11. Using low air pressure, blow free the chips before removing the reamer.
12. To remove the reamer, turn clockwise while slowly pulling outward on the reamer.
13. Remove any remaining debris from the bore with low air pressure and mineral spirits/degreaser cocktail.
14. Lubricate the replacement valve with ATF. Fit the valve into the reamed bore. If snug, repeat the reaming procedure with an air drill at 500 rpm.

## Cautions:

- Never turn the reamer backward.
- Pushing on the reamer will result in poor surface finish, inadequate and sporadic material removal, and material being left unrecovered as the reamer exits a bore.
- Blow free any chips from the reamer after each use.

Note: Ensure that the text on the reamer reads “CD4E Pressure Regulator Valve.”

## Installation instructions

1. Lubricate all parts prior to installation.
2. Refer to the photos on Page 1 for valve order and orientation. All Sonnax parts in the photo are identified with the Sonnax icon .

## End Plugs

To prevent leakage at bore end plugs, a tubing cutter should be used to groove the outside diameter of all valve body end plugs.

Note: Installing these two regulating valves will improve the source of lube/converter feed and prevent high line pressure. They will not overcome a worn bypass sleeve and bypass valve.

A complete fix includes a modified bypass clutch control valve line-up, available in kit **73840-BK**. Both the bypass clutch control kit and pressure regulator kit are sold together in Sonnax Master Kit **73840-MK**.

PART NUMBERS 73840-RK, -RTL

### Lube Circuit Modification

Note: This optional procedure can be performed using the drill bits included in the tool kit. The valve repair kit will function without this process. This procedure increases lube oil and converter pressure, and is suggested in transmissions with high bushing clearances.

1. Lightly countersink (see Figure 1) the CCX (regulated converter charge) hole approximately  $\frac{1}{2}$ " deep on both sides of the transfer plate with a  $\frac{5}{16}$ " drill bit. This will create a shoulder to wedge the aluminum plug onto. Insert the  $\frac{1}{4}$ " diameter x .225" long aluminum plug from this side of the plate and drive until mushroomed tightly. Verify case side of plate is flush, and stone or file if necessary. Drill a .042" orifice hole in this plug. Use a .062" drill bit to taper/countersink the entry side of the .042" hole.
2. On the transfer plate (see Figure 1), drill a .062" hole through the indicated wall. This will connect the line pressure circuit to the lube circuits.
3. Drill orifices "S" and "T" on the control valve body separator plate (see Figure 2) to .062". Insert the small aluminum pegs (.062" diameter x .075" long) into the holes and peen over on both sides.
4. On the transfer plate (see Figure 1), drill a .052" hole through the indicated wall. This will connect the differential and front lube circuits.

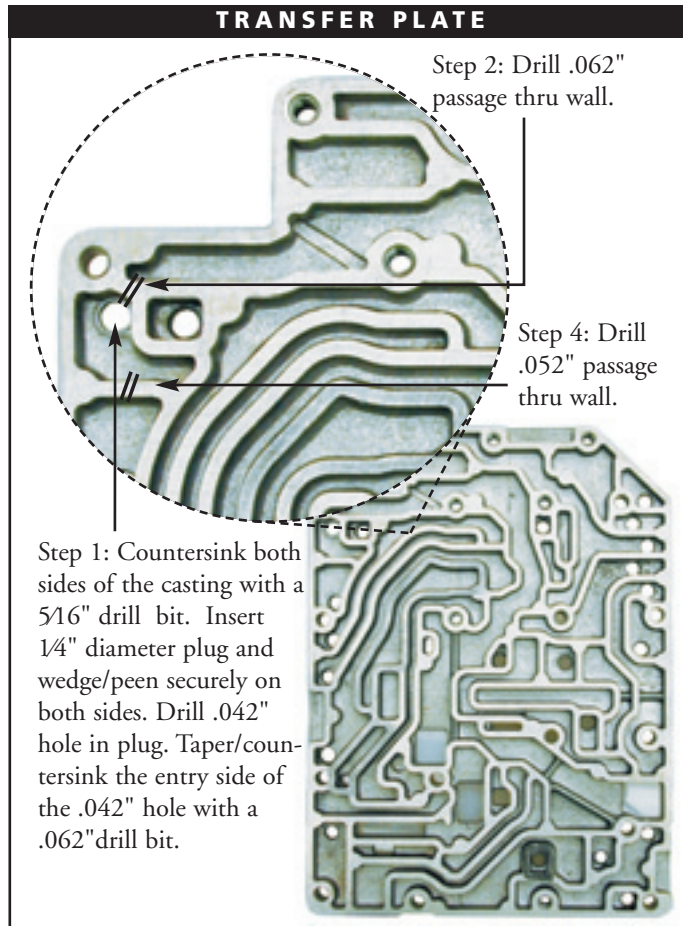

Figure 1

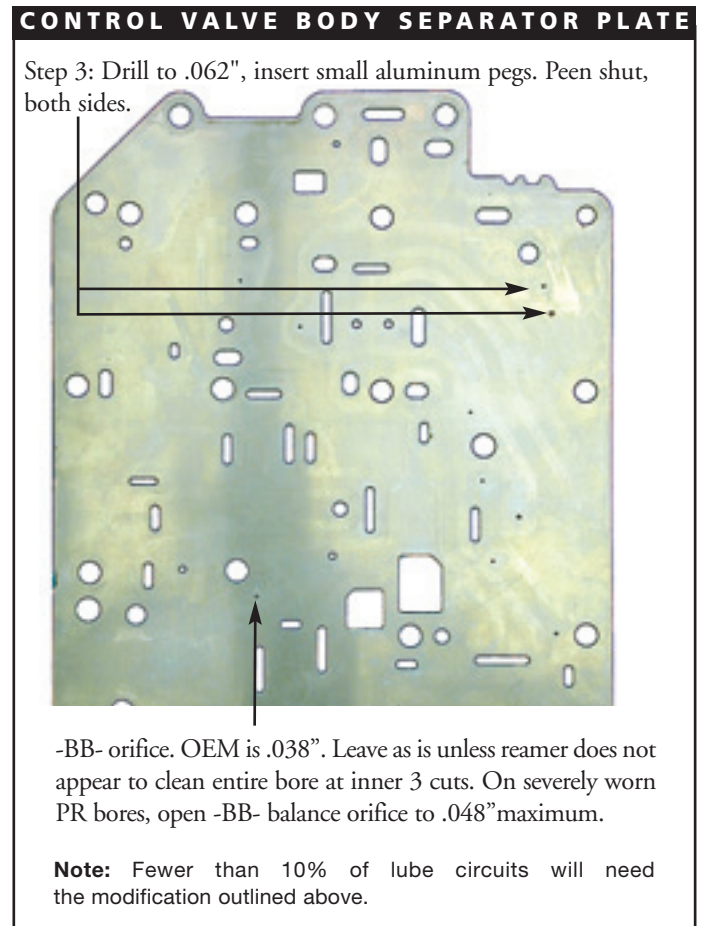

Figure 2